

# GRIZZLY FEEDER



Grizzly Feeder 1500 x 6500

**TTE Grizzly Feeder** is a kind of linear direction feeding equipment. It features smooth vibrating, reliable operation, long service life and being suitable for feeding. They are widely used in mining, building material, silicate and chemical industry in the crushing and screening plants.

**Features of TTE Grizzly Feeder:**

1. Stable and long span life
2. Easy to adjust
3. Reliable operation
4. Easy maintenance

In the sand-stone production line, it can send materials to crusher evenly and continuously and at the same time, it can screen materials roughly. It can be used in these areas such as metallurgical, coal mining industry, mining-selecting, building, chemical and grinding industry, etc.

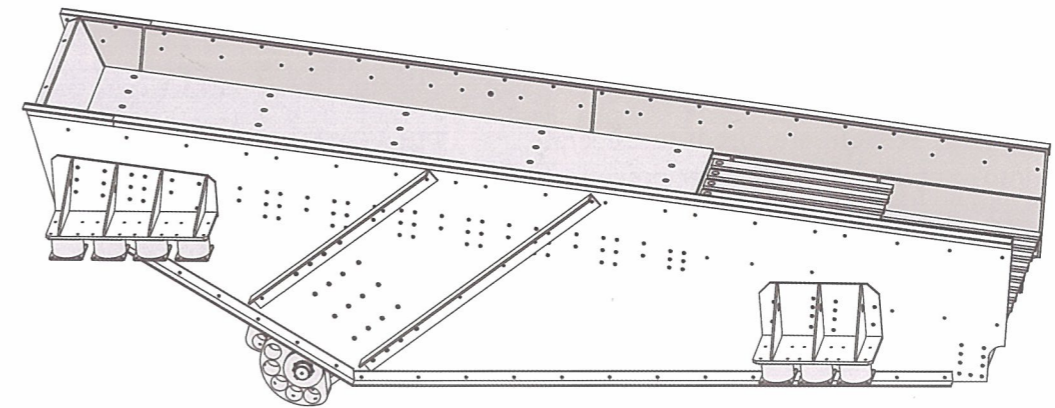

## GENERAL SPECIFICATIONS

Width	From 600 - 1800mm
Length	From 1000 - 7200mm
Capacity	Up to 850 tph
Operating Angle	From 0° - 10° (down)
Drive	Variable Speed, Unbalanced Motors or Exciters

Feeder Size W x L (mm)	Weight kg	Power kw	Capacity tph
600 x 1500	700	1.2 X 2 nos	150
800 X 2000	1000	1.5 X 2 nos	250
1000 x 2000	1500	1.9 X 2 nos	300
1050 x 3000	3600	22	260
1050 x 4500	4700	30	260
1200 x 4500	5000	37	500
1200 x 5500	6700	37	500
1200 x 6500	7000	37	500
1350 x 5000	7000	37	750
1350 x 6000	7500	37	750
1350 x 6500	8000	45	750
1500 x 6500	9000	45	850
1800 x 6500	11000	55	850

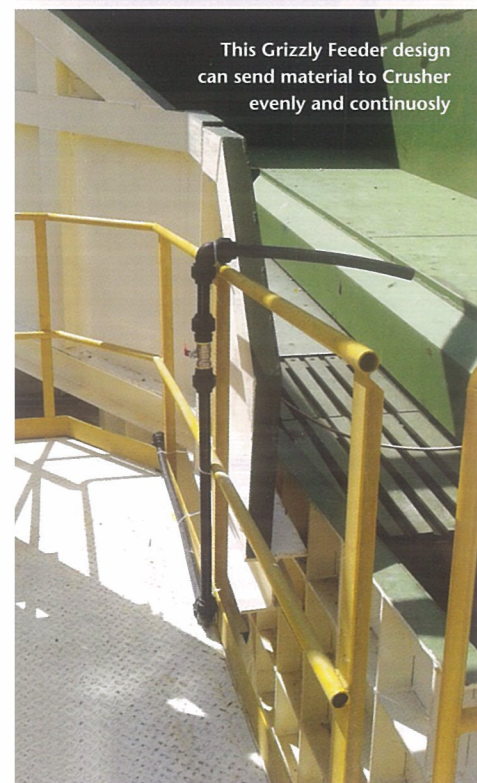

This Grizzly Feeder design can send material to Crusher evenly and continuously



Heavy-duty exciter for Grizzly Feeder

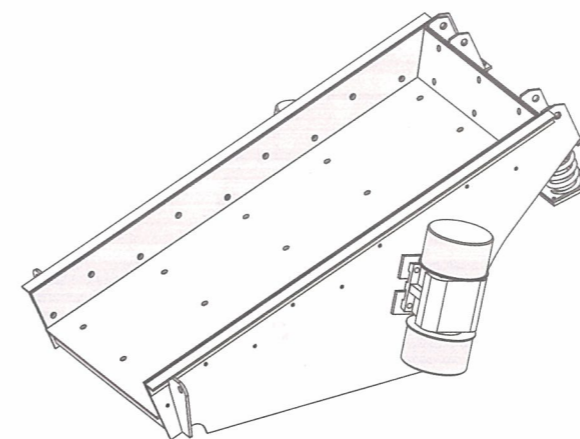

## TTE Pan Feeder



Pan Feeder with Unbalanced Motor